

Zawór przeponowy ZPA DN 15÷40, żeliwny-wygumowany, kołnierzowy Cast-iron diaphragm valve ZPA DN 15÷40 with gum lining and flanges

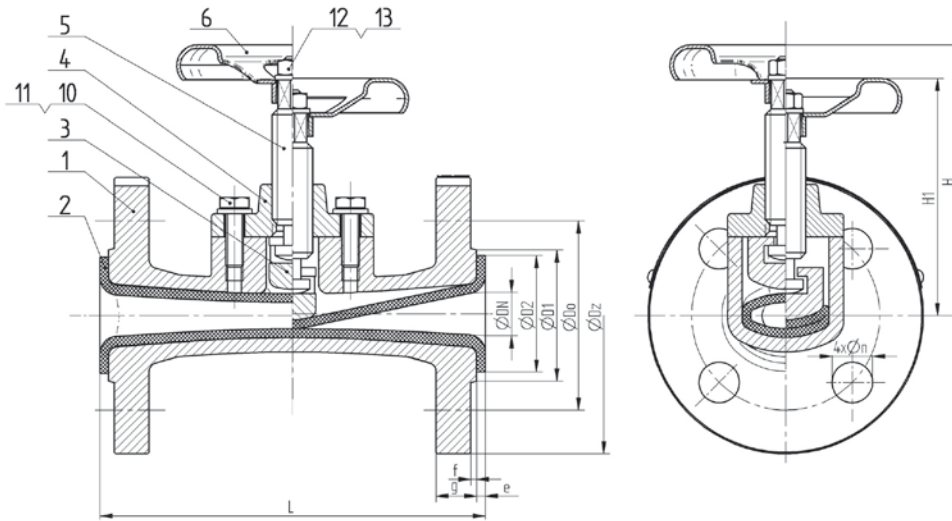

Wymiary gabarytowe i przyłączeniowe Overall and connection dimensions

| ZPA | | Wersja owiercenia Drilling version | Wymiary gabarytowe Overall dimensions | | | | Wymiary przyłączeniowe Connection dimensions | | | | | | | | | | Masa Weight [kg] |
|-----|----|---|--|-----|----------------|----------------|---|----------------|----------------|----|---|---|----------------|----------------|----------------|---|------------------------|
| DN | PN | | | | | | według / according to: PN-EN 1092-2 | | | | | | | | | | |
| | | | L | H | H ₁ | D _k | PN | D _z | D ₁ | g | f | n | d ₁ | D _o | D ₂ | e | |
| 15 | | 2 | 133 (130)* | 93 | 82 | 80 | 6,0 | 80 | 41 | 14 | 2 | 4 | 11 | 55 | 40 | 3 | 1,600 |
| | | 1 | | | | | 10,0 | 95 | 45 | | | | 14 | 65 | | | |
| 20 | | 2 | 155 (150)* | 98 | 86 | 80 | 6,0 | 90 | 52 | 16 | 2 | 4 | 11 | 65 | 50 | 5 | 2,300 |
| | | 1 | | | | | 10,0 | 105 | 58 | | | | 14 | 75 | | | |
| 25 | 6 | 2 | 165 (160)* | 137 | 120 | 100 | 6,0 | 100 | 62 | 16 | 2 | 4 | 11 | 75 | 60 | 5 | 3,200 |
| | | 1 | | | | | 10,0 | 115 | 68 | | | | 14 | 85 | | | |
| 32 | | 2 | 185 (180)* | 144 | 122 | 100 | 6,0 | 120 | 72 | 18 | 2 | 4 | 14 | 90 | 70 | 5 | 4,500 |
| | | 1 | | | | | 10,0 | 140 | 78 | | | | 19 | 100 | | | |
| 40 | | 2 | 205 (200)* | 152 | 124 | 100 | 6,0 | 130 | 88 | 18 | 3 | 4 | 14 | 100 | 86 | 5 | 5,800 |
| | | 1 | | | | | 10,0 | 150 | | | | | 19 | 110 | | | |

* Długość zabudowy zaworów przeponowych wg PN-EN 558 FTF 1 (F1 wg DIN 3202), kołnierze przepon w ZPA są jednocześnie uszczelkami. Producent zastrzega sobie prawo do zmian konstrukcyjnych.

* Mounting length acc. to PN-EN 558 FTF 1 (F1 acc. to DIN 3202). Flanges of the diaphragms are simultaneously seals. Producer reserves the right for construction changes.